

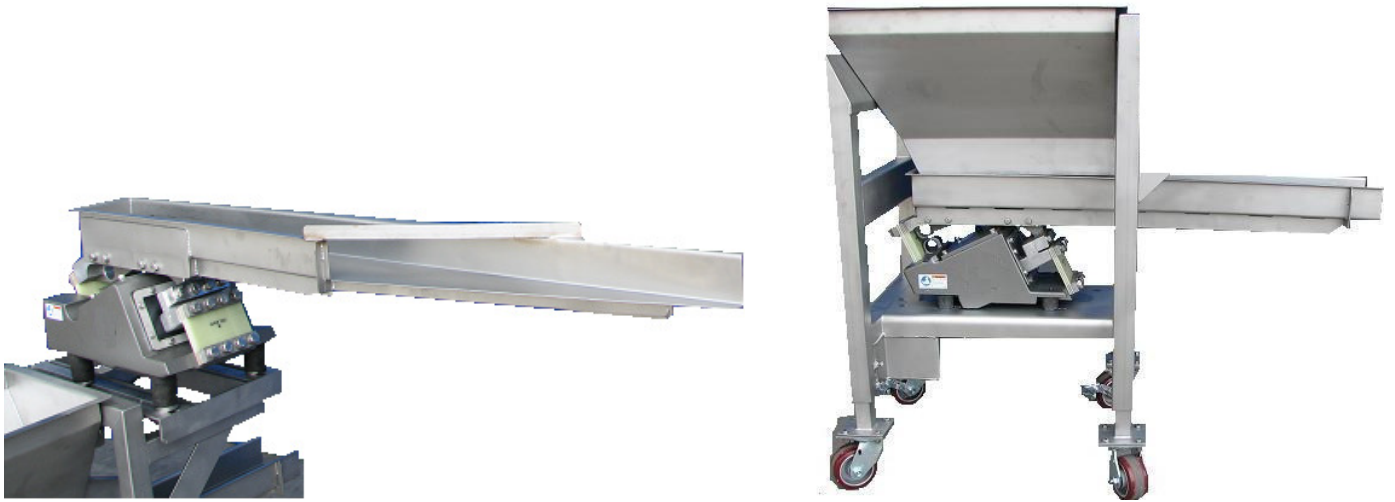

# VIBRATORY “SCARF” AND “HOPPER FEEDERS”



- **SIMPLE RELIABLE CUSTOM FEEDERS**
- **MAGNETIC DRIVES FOR PRECISE PRODUCT CONTROL**
- **“SCARF” SPREADING FEEDERS FOR BAND FEEDING, SEASONING, AND BLENDING.**
- **“HOPPER-FEEDERS” FOR PRODUCT “ACCUMULATION” AND REGULATION OF PRODUCT FLOW**
- **MOUNTING OF UNITS CAN BE ON STAND, CASTORS, OR HANGERS**
- **TYPICAL 110/230 VOLT SINGLE PHASE VARIABLE FREQUENCY CONTROL.**

**DESIGNED FOR YOUR PRODUCT AND YOUR  
APPLICATION.**

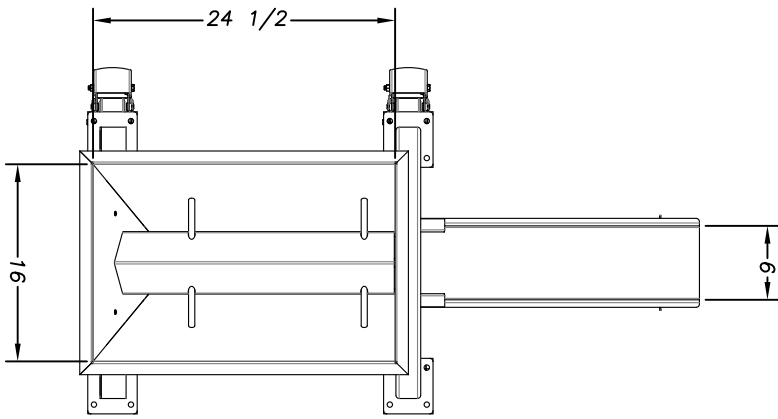

DIMENSIONS ARE FOR REFERENCE ONLY  
PLEASE CONTACT US TO MAKE AN APPLICATION  
TO SUIT YOUR NEEDS

